

LIGHTNIN FOR SERVICE

Lightnin Process Equipment Services (LPES): The Fastest Route To Uptime.

Expertise: LPES technicians are the backbone of our dedicated service organization. They're uniquely qualified to keep your LIGHTNIN mixers running right.

Lightnin Certified Technicians: All LPES technicians are certified via training courses to ensure that the work they do meets the highest standards for consistency and reliability.

Genuine LIGHTNIN Parts: All LPES repairs follow original design specs and use only factory-authorized replacement parts.

Full LIGHTNIN Factory Warranty: We're so confident we'll do the job right that all LPES repair and service work is covered by a full factory warranty. What we repair, we guarantee – 100%.



Lightnin Attrition Scrubber Demo Units -

1.5 liter and 14 liter pilot equipment is available for loan or purchase to demonstrate the value of LIGHTNIN Attrition Scrubbers in your process. Contact your local LIGHTNIN representative to arrange a complete test.

Call the LIGHTNIN Experts

For more information about LIGHTNIN's Attrition Scrubbers or to discuss your application, contact your local LIGHTNIN Sales Representative. Or visit our website at www.lightninmixers.com.

Or call 1-888-MIX-BEST (U.S. and Canada), or 1(585) 527-1623 (worldwide).



Installation:
10 off 20 cubic meter Attrition Scrubbers
Anglo Platinum – Potgietersrust Platinum

LIGHTNIN

*The Leaders in
Process Technology*

135 Mt. Read Blvd.
Rochester, NY 14611 USA
www.lightninmixers.com

LIGHTNIN

The Leader in Mixing Technology

Attrition Scrubbers

A modern solution to an old standard.



“We Did Not Invent It, Only Perfected It” – Lightnin Injects its Mixing Knowledge and Technology to Attrition Scrubbers - By Revolutionizing Recoveries, Process and Plant Operations, and Product Quality.

With over 75 years of experience, Lightnin is constantly developing new methods of mineral processing to offer innovative solutions and advanced technology to the industry. Attrition Scrubbers have been accepted in the minerals industry for many years, removing surface particles and contamination from a wide range of materials including: Platinum and Palladium, Glass, Sand, Phosphate, Coal, Slaked Lime, Copper, Nickel, Kaolin and Plastic Recycling.

Attrition: A rubbing out or grinding down, as by friction or a gradual wearing down or weakening: a war of attrition.

Scrubber: Any apparatus that removes unwanted material through the medium of a liquid by washing.

Choose LIGHTNIN for Process Performance

LIGHTNIN is the world leader in fluid mixing technology. We've taken this expertise and applied it to Attrition Scrubbing. Through the use of computation modeling and field installations, the LIGHTNIN Attrition Scrubber offers unparalleled process performance.

Controlled Retention Time:

- Insures Optimum Attritioning
- Deflector Plate Prevents Short Circuiting

Controlled Flow Rate:

- High Efficiency Pumper Impeller
- Adjustable Weir Slats at Outlet

High Intensity Mixing:

- Two Engineered Impellers Optimally Spaced
- Fully Baffled Attrition Chamber
- High Shear Rate

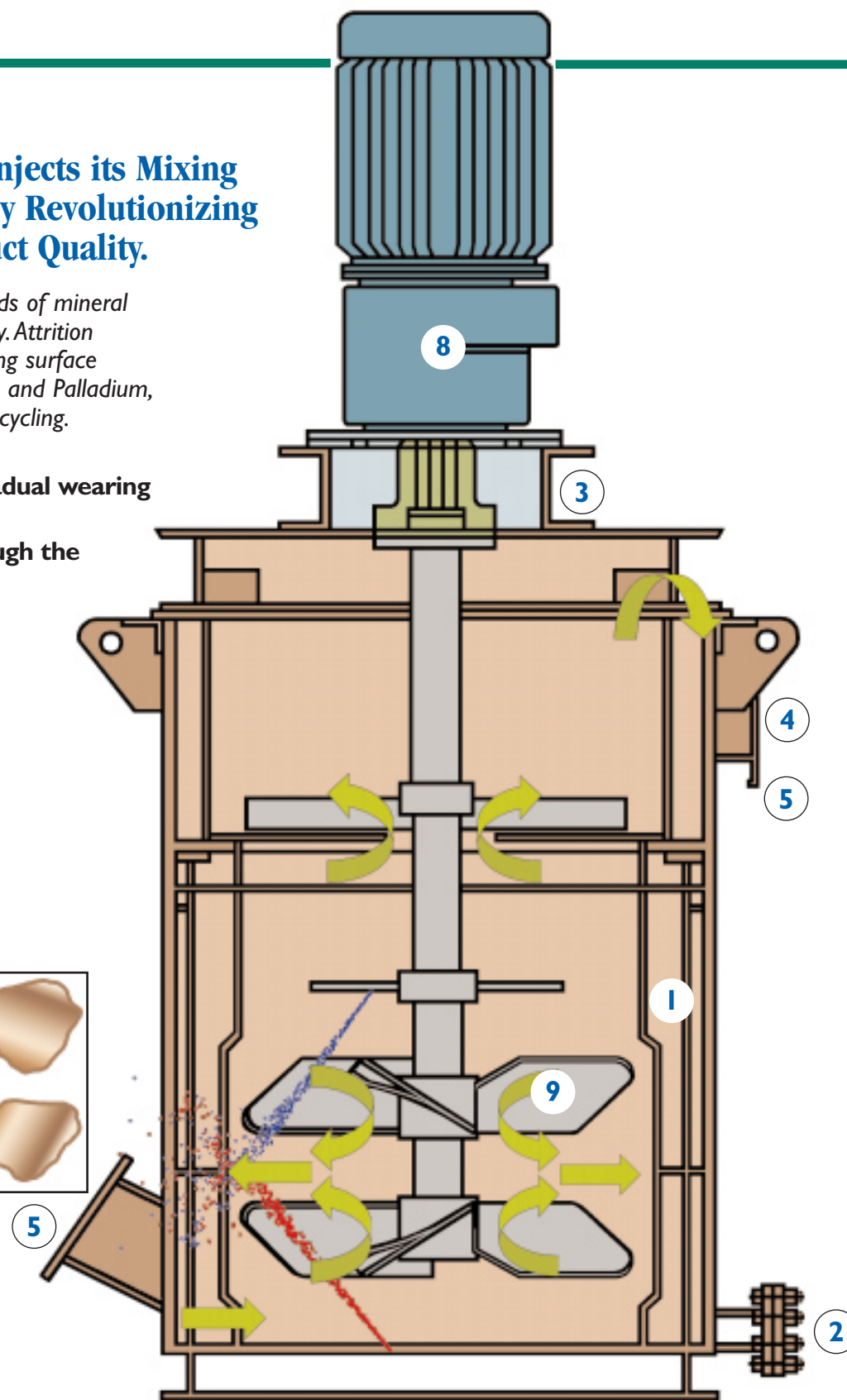
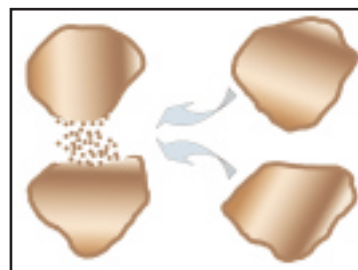

The LIGHTNIN Advantage

- No Vortexing
- Minimum Erosion
- Improved Mechanical Reliability
- Improved Process Results
- Proper Solids Suspension

Choose LIGHTNIN for Mechanical Reliability

- 1 Fully Baffled Chamber with a gap between cell wall and baffles to prevent solids build-up.
- 2 Automatic drain valves fitted to allow removal of solids and easy restart.
- 3 Design allows for removal of the complete rotating assembly as a single unit for simple maintenance and installation.
- 4 Multiple cells are connected with a flexible rubber hose to compensate for any civil or structural variations.
- 5 Slurry feeds from bottom and exits through top in each stage.
- 6 Identical drive and tank cells allow for flexibility in process and maintenance.
- 7 Independent, allows for simple and economical by-pass facilities to be designed.
- 8 Gearbox designed for heavy-duty continuous operation.
- 9 All internal components coated with an extra heavy layer of natural rubber.

Heavy-duty rubber coated shafts for long life and reliable operation.



Case Study

For one of the world's largest platinum producers, a LIGHTNIN Attrition Scrubber has improved Platinum recovery by 4 to 7 percent, this translates into millions of dollars per year. The new machine has proven to have lower operating cost due to its improved efficiency.